



ASS190

Slide Stainer

Operation Manual

AMOS SCIENTIFIC PTY.LTD. ABN:37 159 778 140

www.amos-scientific.com

Foreword

Thank you for purchasing our ASS190 Slide Stainer. This operation manual introduces product function, application method and matters need attention for safety. Please read in detail before operation to facilitate your better understanding of product performance and full utilization of each function. For any questions, please contact us and we provide satisfactory service at any time.

After completion of reading, please keep the manual properly for later reference.



Contents

1. Safety Matters	- 1 -
2. Technical Structure	- 2 -
2.1 Performance	- 2 -
2.2 Technical Parameters	- 3 -
2.3. Distribution of Liquid tank	- 3 -
2.4. Structure Distribution Diagram	- 4 -
3. Operation Guide.....	- 5 -
3.1 Display Panel.....	- 5 -
3.2 Screen LCD display explanation	- 6 -
3.3 Operation	- 8 -
4. Trouble Shooting	- 11 -
5. Maintenance.....	- 11 -



1. Safety Matters

●Please read these explicit rules. Act in violation of them can affect normal operation of the equipment, cause damage to the equipment or result in danger.



◆ Please use 220V±10%, 50Hz or 110V±10%, 60Hz AC..



◆ Input power supply must be of good earth connection.



◆ Keep away from flammables and explosives.



◆ Don't open equipment without authorization to avoid high voltage shock.



◆ Only professional maintenance personnel is allowed to repair equipment.



◆ Use fuses with correct capacity.



◆ Ensure power socket and circuit be able to bear 2 times of rated current at least.



◆ Keep away from from any interference source.

■ **Electrical Protection Ratings: I class, B type**

■ **Baleful liquid Leak-in proof degree: Normal (enclosed equipment without liquid leak-in proof)**

■ **Working system: Continuous running**

●Conditions of Installation

●Ensure more than 20cm of space around the equipment for heat dissipation.

●No water drop, steam, dust including oily dust and floating dust.

●No erosive,flammable and explosive gas and liquid.

●Solid and non-vibration.

●No interference from other electromagnetic signals.

●Operating ambient temperature from 0°C to 50°C ,relative humidity under 90%

● Delivery inspection

Product has been through strict inspection by quality management before ex-factory. However, product may be damaged or partially lost due to negligence or severe clash during delivery. Thus

- 1.Please check the contents inside including equipment, operation manual, packing list and spare parts after unpacking,
- 2.Check nameplate to ensure it is your order.
- 3.Make sure of no damage or loss during delivery..

2. Technical Structure

2.1 Performance

● The machine uses CPU microcomputer control technology, has advanced intellectualized control system.

A、 Various Functions

- ① Besides conventional stainer function, it also has the function of flexible program to adapt different technical process and new technical test, the system can begin or end at any tank as required and the max step of the machine is 25 steps.
- ② The system can stores Eight different programs which is applicable to various tissue processing. It also has bath function.

B、 Security

- ① The system has full protection functions. Even abnormal conditions or misoperation could not damage the equipment.
- ② It has automatic position search function, the basket can find out any set position.
- ③ It has alarm function. It judges the operation carried out by the operator and do not carry out the misoperation for the operator to correct.
- ④ It uses high-performance stepping motor system to ensure the machine is running steadily , with low noise and can position accurately.
- ⑤ Air filter device to reduce air pollution.
- ⑥ Sealed soft-feel control panel is operated reliably ,dustproof and waterproof.
- ⑦ The streamline shape appearance makes it easier to clean.
- ⑧ It has inlet and outlet water hose which makes to wash the tissue at any time.

2.2 Technical Parameters

- Quantity of slide racks: 2
- Throughout capacity: 96 slides at a time(48 slides on each slide rack)
- Quantity and capacity of containers: 19, 800ml for each container (The first and second station is for water)
 - Retention period in each tank: 1 minute~90 minutes 59 seconds(it can be set at will)
 - Agitation time can be set as requirement from 5-30seconds(the default value is 15seconds)
 - Memory Storage: 8 programs available
 - Power supply: 220V \pm 10% 50Hz or 110V \pm 10% 60Hz
 - Fuse: 220V:2A /110V:3A
 - Power: 120W
 - Dimension: 1235mm \times 475mm \times 590mm
 - Weight: about 75Kg

2.3. Distribution of Liquid tank

1	2	3	4	5	6	7	8	9	10	11	12	13	14	15	16	17	18	19
Water	Water	Hcl-alcohol	Hematoxylin	Eosin	Dimethyl benzene			alcohol							Dimethyl benzene			
								100%	95%	85%	70%	75%	85%	95%	100%			

Commendatory Program

Program 1	Step	1	2	3	4	5	6	7	8	9	10	11	12	13	14	15	16	17	18	19
	Tank	6	8	9	10	11	12	1	4	1	3	1	5	1	13	14	15	16	17	18
	Time (Minute)	11Min 30sec	5	5	3	3	2	3	5	3	1 sec	3	2	2	2	2	2	2	2	2
Program 2	Step	1	2	3	4	5	6	7	8	9	10	11	12	13	14	15	16	17	18	19
	Tank	7	8	9	10	11	12	2	4	2	3	2	5	2	13	14	15	16	17	19
	Time (Minute)	5	5	5	3	3	2	3	5	3	1 sec	3	2	2	2	2	2	2	2	2

Note: The Beginning tank is from Tank 6 & Tank 7 (the basket is staying in tank 6 waiting to run the program 1 and other basket in tank 7 waiting to run program 2). Press key **RUN**, the system will test the basket in the beginning tank automatically or not, if the two baskets all stay well in the Tank 6 and 7, the instrument will run the program 2 firstly, and then run the program 1. The system provides eight programs be edited. (Note: when programming, make sure the basket in tank 6 running don't overtake the basket in tank 7 to avoid getting stuck, if meet the stuck, the long buzzer rings will remind user. So, PLEASE NOTE:1. Staying time of basket in the tank 6 is more than tank 7, the others time programmed should be the same.

2. The finished tank should be not the same.

3. Water in tank 1 for program 1 , Water in tank 2 for program 2.

2.4. Structure Distribution Diagram

- 1) Hanging basket
- 2) Sealing cover
- 3) Water
- 4) Front panel with display LCD
- 5) Plexiglass glass housing

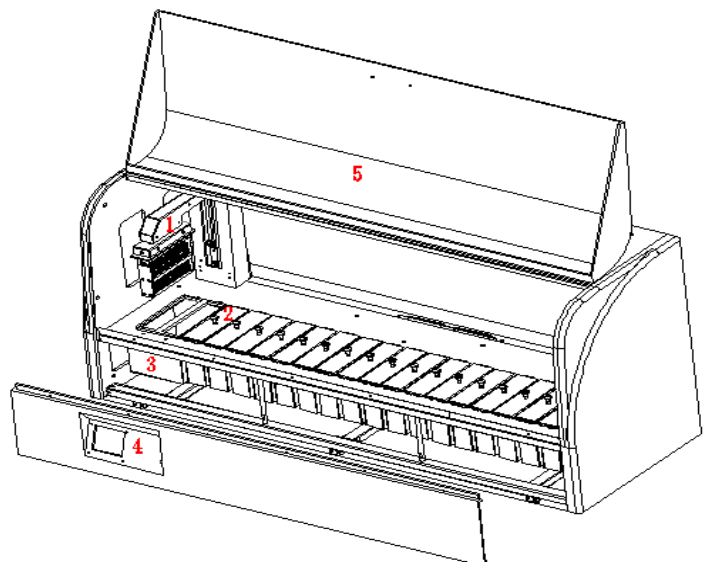

- 6) Power switch
- 7) Switch and Socket
- 8) Fiber Carbon filter
- 9) Filter
- 10) Switch Power supply
- 11) Electric Control Box and Driver
- 12) Rear Cover

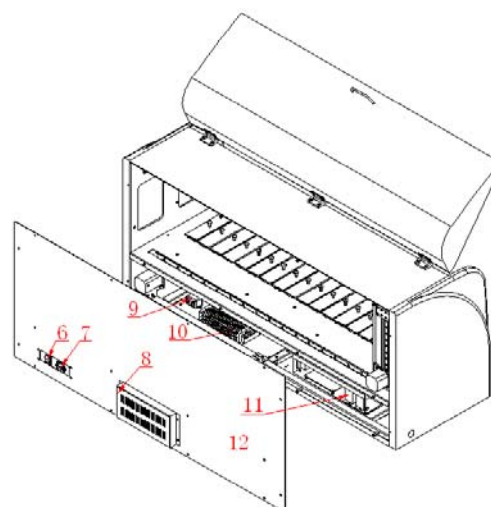

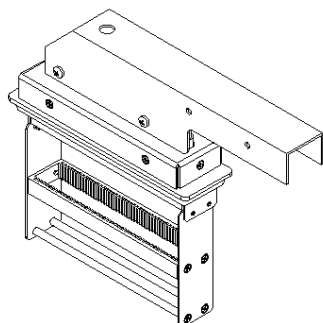

Hanging basket

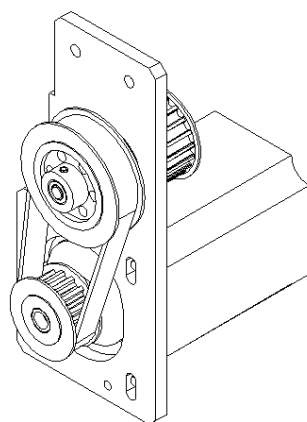

Movement unit

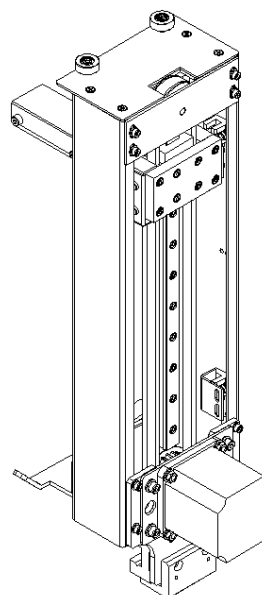

3. Operation Guide

3.1 Display Panel



A、 Key explanation

Standby It can be activated in Auto or Manual mode, press this key and the machine will stop running or start to running.

Program It can be activated in main menu, check window and program state. The operator can press this key into check window from the main menu, and press this key into program state from check window while press this key again to set each program.

Run It can be activated in main menu when it is in Manual mode, press this key the machine will enter into Auto mode.

Valve It can be activated in main menu when it is in Manual mode, press this key to control the valve open/close.

Restart It can be activated in Auto or Manual mode, press this key to make the machine back to the initial status.

Exit It can be activated in Auto standby or Manualmode. Main Functions : The operator can press this key to back to main menu from checking window, and press this key to back to check window from programming state, and press this key to back to main menu when it is in Auto or Manual mode.

Manual It can be activated in main menu when the machine standby in Auto mode or running finish. The operator can press this key into manual mode.

Magnet It can be activated in Auto or Manualmode, press this key to start or stop to run the magnet.

↑ ↓ It can be activated in main menu , manual mode or program state. The operator can press these keys to select required program in main menu, and press these keys to set value while it is in program state and to control the basket move up and down in manual mode.

← → It can be activated in manual and program state, check window display. The operator can press these keys to modify the running steps when it is in program state or checking window, and to control the basket moving to right and left in manual mode.

3.2 Screen LCD display explanation

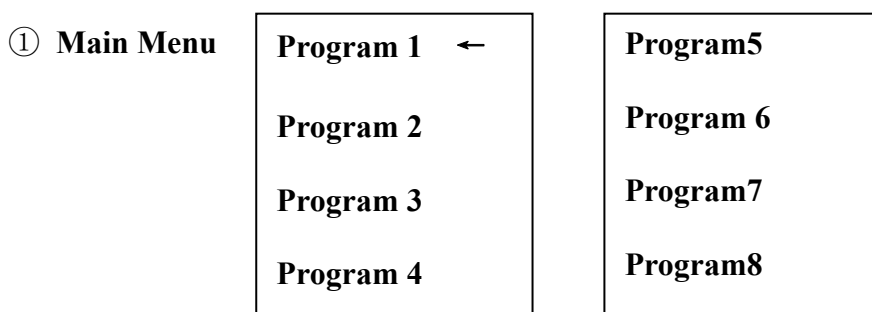

Notes : There are 8 programs(4 groups) available, and “←“shows the current selected program.

② **Check window and Program window**

Check		Program	
Step: 01	Time: Min: 01	Step: 01	Time: Min: 01
Tank: 06	Sec: 01	Tank: 06	Sec: 01
Time-delay: Sec: 02		Time-delay: Sec: 02	

③ **Manual Mode**

Manual		
State:	Valve:	ON
↓		

It displays the water valve state on the ON/OFF, ↓ shows the basket is moving down.

④ **Auto Mode**

Step: 02	Program 1
Tank: 07	Auto
Valve: Open	
Time: 01:01	Waiting

Notes : In automatic running mode, the window displays : the basket running step, tank number, Valve state, the rest time to finish this step, and the state of basket(waiting, rock, vat block, standby, ending and so on). As the picture showed, the basket is running to step 2, tank 7 ,Valve is open and the rest time is one hour and one minute to finish , the basket is in waiting state.

3.3 Operation

3.3.1. How to Check

- * In the main menu, press key to select the program user wants to check. *And then press key to enter into the check window
- * Then select the required step by to check its parameters
- * After finishing the checking, press key to back to the main menu.

3.3.2. How to Program

- * In check window, press key to enter into program state
- * And then select the step you want to program by
- * When the step selected, press circularly to select the parameter for setting in turn: tank number and time. The flickering icon will lead the user to set the corresponding value by
- * The time of Agitation and dripping waiting can be selected by . The agitation time is same for eight programs, and the dripping waiting time of each step in different protocol can be set separately.
- * The beginning step of Program 1,3,5,7 is tank no. 6, and the beginning step of Program 2,4,6,8 is tank no.7.
- * If the ending tank doesn't need to be finished at the last tank , the user should set the next tank of required ending tank as 00, but its time could not be set 00. (Note: The ending tank of Program 1,3,5,7 should be set before the Program 2,4,6,8 to avoid two baskets barge against at the finishing)
- * After finishing the programming, press back to the check window.
- * The set value could be automatically stored and loaded when the machine startup next time.

3.3.3. Operation in Manual Mode

- ① In main menu or the machine pause in Auto mode, press to enter into manual operation mode.
- ② The basket can be moved by
- ③ Press to open valve or close.

- ④ Press key **Exit** to back to main menu, and press key **Restart** to restore the machine and back to the main menu.

3.3.4. Operation Auto Mode

- ① In the main menu, select the running program by **↑ ↓** .

(Attention: Program 1 and 2 is in one group, on the analogy of this, Program 3 and 4 is in one group, Program 5 and 6 is in one group, Program 7 and 8 is in one group.)

- ② Press key **Run**, the system will check the basket automatically, and after it, it will run automatically.

- ③ If there is any problem when the system is in automatic running, modify the procedure according to the tissue staining effect as following:

- Press **Standby** to pause the running and then press **Manual** to enter into manual operation, and observe the dehydration effect .

- Press **Standby** and then **Exit** to back to main menu and then press **Program** to check and modify current procedure.

- In main window or manual mode, press **Run** after standby, the system will continue running from the standby position automatically.

- ④ Press **Restart** in the running process, system will exit Auto running state automatically, and the machine restore and back to the main menu.

- ⑤ After finishing the running, press **Manual** to do the manual operation, and take out basket by **Magnet** and **↑ ↓ ← →** . And then press **Restart** to restore the machine and back to main menu, and wait for next running.

- ⑥ Only one basket be load before the running, press **Run** to start running the program indicated by a arrow. If you want to insert another basket running, steps of operation are as follows:

*press **Standby**, and then press **Exit** to back to the main menu,

* choose the required program, and press **Run** to start running.

(Note: The inserted basket is only limited to run from the beginning tank. And if the number of running program is odd, the inserted program should be even, then we can avoid the conflict of running time, ending tank, washing tank and so on.)

3.3.5. How to Set protect tank and delay time function

- ① Press in the main menu to enter into protect tank and delay time set.
- ② Press to select protect tank or delay time to set it when it is flickering.
- ③ Modify the protect tank or delay time value by .

Attention: it could be set two protect tanks and the unit of delay time is hour.

3.3.6. The second operation

You can use the second operation function when you meet the dyeing effect proceed not good in the first time staining or automatic interruption, steps of operation are as follows:

- ① Press in the check window, enter into the edit the beginning tank of second operation, and press key to confirm the beginning tank.
- ② Put the basket into the beginning tank and press into the second operation.

Notes: You can run the selected one program when in the second operation, but it can start running from any tank, but please pay attention, the beginning step must be from the first washing tank.

- ③ Choose the program you require to run, enter into the program window, then find out the corresponding step. Press after you check whether the tank number of this step is the same as the stay tank number of the basket.

Notes: Only two programs are allowed to run at the same time, regardless of the way in which you insert the program.

3.3.7. Attention matters in operation process

When the first running of the instrument or the set time is modified, there may be one basket not to run, of which the reason maybe the time clash in the two programs (when runs program 1 and 2 automatically),

please add one more minute to the first step in program 1, which could solve the problems.

4. Trouble Shooting

Symptom	Cause	Remedy
Fan out of work	Fan broken	Replace the Fan
Hanging basket would not move.	Damaged driver of stepping motor	Replace the stepping motor
Tank cover would not be opened or closed.	(a) Jammed by obstruction	Remove the obstruction
	(b)damaged spring	Replace the spring
All doesn't work except of fan	2A fuse broken	Replace the 2A fuse

5. Maintenance

Please carefully read this operation manual before operation. Operation should be done according to the requirements stipulated.

- (a) When the direction keys are pressed during manual operation, if the basket is already in the limited position, the system will ignore the instruction.
- (b) Keep the machine tidy and clean and protect it from being stained with liquid, wax and dust.
- (c) Lubricant should be added to the transmission parts to ensure normal operation.
- (d) Don't add too much liquid to the tanks to prevent the damage to the parts and components caused by overflow of the liquids.
- (e) Handle the liquid tanks carefully to avoid the damage to them which will cause leakage.

Standard accessories list

No	Accessory Name	Qty	Notes
1	Stainer	1set	
2	Power Cord	1pc	
3	Fuse	2pcs	220V:2A/110V:3A
4	Basket	2sets	
5	1.5M Soft tube	1pc	
6	Corner valve	1pc	
7	Three way pipe	1pc	
8	Connector	4pcs	
9	Pointed valve pipe	1pc	
10	Teflon Tape	1Roll	
11	Waste Water pipe	1.5M	(blue color)
12	Operation Manual	1pc	

Published by:

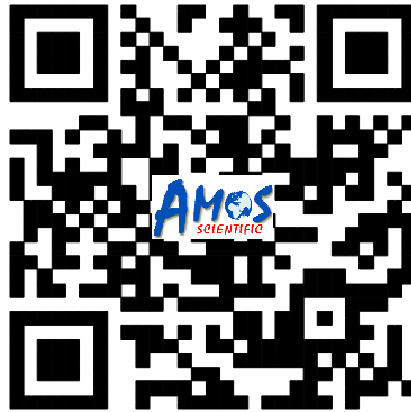

AMOS SCIENTIFIC PTY.LTD.

7 Gabrielle Court, Bayswater North VIC 3153 Melbourne , Australia

Tel: +61-410190188 Fax: +61-410190188

ABN 37 159 778 140

www.amos-scientific.com